



Facts at a Glance

March 2010

Author: Yuval Hernik
Tel: 972-355-70852
E-mail: Yuval.Hernik@vishay.com

How Strain Gage Bridges Work with Hermetically Sealed Precision Resistors Based on Z-Foil Technology

What is a strain gage?

A strain gage is a device used to measure the surface strain (unit deformation) on an object. The most common type of strain gage consists of an insulating flexible backing which supports a metallic foil resistor. The gage is attached to the object by a suitable adhesive. As the object is deformed, the foil is deformed, causing its electrical resistance to change. This resistance change, usually measured using a Wheatstone bridge, is directly proportional to the surface strain on the object.

The strain gage has been in use for many years and is the fundamental sensing element for many types of sensors, including pressure sensors, load cells, torque sensors, position sensors, etc. The strain gage is connected into a Wheatstone Bridge circuit with a combination of four active gages (full bridge), two gages (half bridge), or, less commonly, a single gage (quarter bridge). In the half and quarter circuits, the bridge is completed with precision resistors.

The complete Wheatstone bridge is excited with a stabilized DC supply and, with additional conditioning electronics, can be zeroed at the null point of measurement. As strain is applied to the bonded strain gage, a resistive change takes place and unbalances the Wheatstone bridge. This results in a signal output related to the strain value. As the signal value is small (typically a few millivolts), the signal conditioning electronics provide amplification to increase the signal level to 5 V to 10 V, a suitable level for application to external data collection systems such as recorders or PC data acquisition and analysis systems.

As the strain gage is either compressed or tensioned, its resistance will decrease or increase, respectively, thus unbalancing the bridge and producing an indication at the voltmeter.

When are ultra-high-precision resistors needed?

One area of measurement technology that requires precision resistors is in the Wheatstone bridge circuit of a sensing circuit. Strain gage measurements are one such application. Typically the strain gage is one arm of a four-arm Wheatstone bridge with precision resistors comprising the other three arms (Fig.1). Some applications may use strain gages in two arms with two precision resistors in the other arms, and in some cases all four arms may be strain gages. In Fig.1 the Wheatstone bridge may use excitation voltages of anywhere between 1 V and 10 V, depending upon the strain gages

Vishay Intertechnology, Inc.

63 Lancaster Ave, Malvern, PA, 19355, +1 (610) 644-1300 Fax (610) 889-0935 www.vishay.com

ONE OF THE WORLD'S LARGEST MANUFACTURERS OF DISCRETE SEMICONDUCTORS AND PASSIVE COMPONENTS



and the applications. The bridge-completion resistors typically have values of 120 Ω , 350 Ω , or 1000 Ω . When the bridge circuit is first set up, it is adjusted to offset tolerance differences to be a balanced bridge, with point A and point B at the same voltage. With points A and B both at the same voltage there is no output from the bridge and the bridge is balanced — but only in its initial stage with no mechanical strain input to the strain gage. When the object to which the strain gage is attached experiences a micro-level deformative load, the concurrent deformation of the strain gage registers a change in resistance proportional to the amount of strain experienced by the device being monitored. The change of resistance unbalances the bridge, producing a voltage differential between points A and B, and this voltage difference is fed through the output leads of the bridge to an amplifier that brings the millivolt-level voltage up to voltage levels more easily processed or recorded.

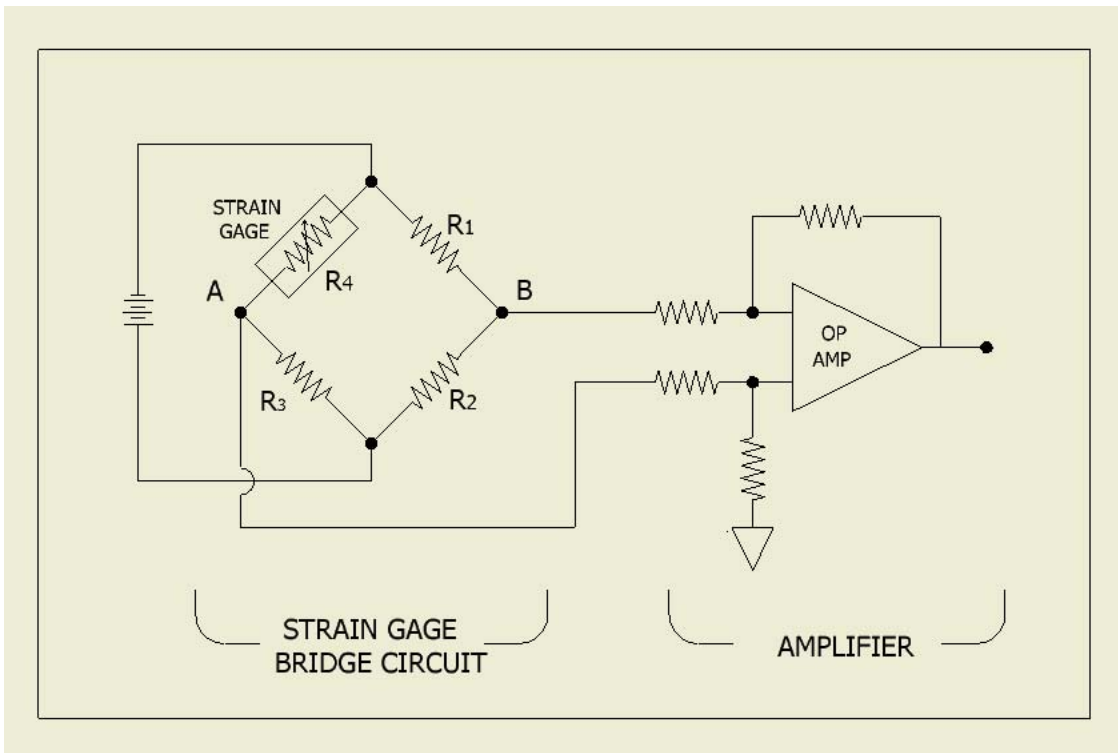

Fig.1

Many applications require multiple strain gages to measure multiple strain positions at the same time. Such would be the case, for example, of strain monitoring of the surface of an airplane wing where 20 or more strain measurements are made simultaneously. In these cases, multiple channels of strain gage bridge-completion networks are all monitored at the same time, and the outputs of all are fed directly into a computer to analyze the simultaneous strains across the aircraft at a particular point in time or external loading condition.

The measurements are very demanding and many precautions are taken to minimize error. For example, the adhesive bond thickness is kept as thin as possible. The wire leads from the gages are twisted to reduce induced currents/voltages from electromagnetic fields and radiation from fluorescent lights, etc. However, after all possible physical precautions are taken, the circuits are still subject to errors due to the

Vishay Intertechnology, Inc.

63 Lancaster Ave, Malvern, PA, 19355, +1 (610) 644-1300 Fax (610) 889-0935 www.vishay.com

ONE OF THE WORLD'S LARGEST MANUFACTURERS OF DISCRETE SEMICONDUCTORS AND PASSIVE COMPONENTS



resistors themselves. While the bridges may have been balanced at the no-load condition, this changes immediately when the circuit is activated and current flows through the resistors. Errors are then introduced due to differential temperature coefficients causing differential resistances as the resistors heat up. Differential heat dissipation also causes differential resistances. Uneven heat dissipation causes the resistors to have thermal gradients across them and this means greater thermal electromotive forces (EMFs) at the leads producing error voltages that unpredictably add or subtract from the intended measurement. Such changes may be ignored in some circuits, but in strain gage bridge circuits the error voltages are at levels high enough to produce significant error. For example, 10 V of excitation voltage across a bridge with 120- Ω resistors generates 42 mA current through the resistors with nearly a quarter-watt of power dissipated in each resistor.

This could easily run some resistor technologies up to 30 °C to 40 °C, with uneven dissipation, high differential temperature coefficients, and with high thermal EMFs in the range of 45 $\mu\text{V}/^\circ\text{C}$. Error signals could easily be in the range of 50 μV to 70 μV while the strain gages are generating 500 μV (0.5 μV from 1 microstrain with 1-V excitation). The result could be measurement errors of up to 10 %. This is why the best solutions for precision strain gage measurement rely on Bulk Metal[®] Foil resistors in the bridge-completion circuits and in the differential amplifier circuits. Bulk Metal Foil resistors feature a temperature coefficient of resistance (TCR) of only 0.2 ppm/ $^\circ\text{C}$ or less, as opposed to other resistor technologies with TCRs of 5 to 15 ppm/ $^\circ\text{C}$. Additional features include a voltage coefficient of less than 0.1 ppm/V, internal temperature rises of only 9 °C/0.1 W, current noise of less than -40 dB, and thermal EMF of less than 0.05 $\mu\text{V}/^\circ\text{C}$.

Consequently, the corresponding error using Bulk Metal Foil is less than 1 μV compared to 50 μV to 70 μV with other resistor technologies.

Vishay Bulk Metal Foil resistors are available in many sizes, configurations, and mounting technologies.

For more information about precision resistors, please contact us at: Foil@vishay.com.

Vishay Intertechnology, Inc.

63 Lancaster Ave, Malvern, PA, 19355, +1 (610) 644-1300 Fax (610) 889-0935 www.vishay.com

ONE OF THE WORLD'S LARGEST MANUFACTURERS OF DISCRETE SEMICONDUCTORS AND PASSIVE COMPONENTS